

**APPLICATIONS**  
**Hyundai Azera**  
**2006-2009**

**CT23HY06**

**KIT FEATURES**

- Double DIN Radio Provision
- Stacked ISO Units Provision



**KIT COMPONENTS**

- A) Double Din Trim Plate • B) Double DIN Brackets

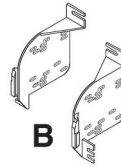
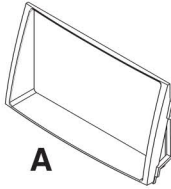

**TOOLS REQUIRED:**

- Small Flat Blade Screwdriver/ Panel Removal Tool  
• Phillips Screwdriver



## **TABLE OF CONTENTS**

### **Dash Disassembly**

**- Hyundai Azera 2006-07 ..... 1,2**

### **Kit Assembly**

**- Double DIN Radio Provision ... 3**

**- Stacked ISO Units Provision . 4**

**Final Assembly ..... 5**

#### **\*Note:**

**Refer also to the instructions included with the aftermarket radio.**

## **HYUNDAI AZERA 2006-2009**

- 1** Disconnect the negative battery terminal to prevent an accidental short circuit.
- 2** Remove (1) Phillips head screw from bottom right hand corner then unclip and let the panel below the steering column hang. (Figure A)
- 3** Remove (1) Phillips screw from the lower left side of the radio panel behind panel removed in step 2. (Figure B)
- 4** Unclip and remove the trim panel above the radio that extends across the dash to the passenger side. (Figure C)

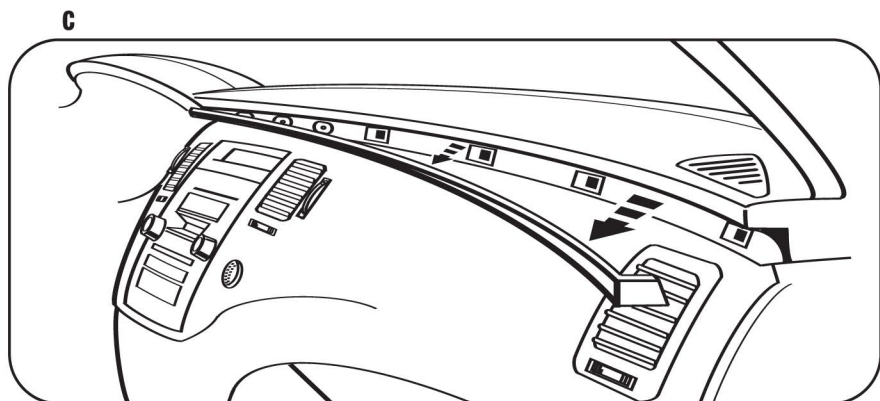
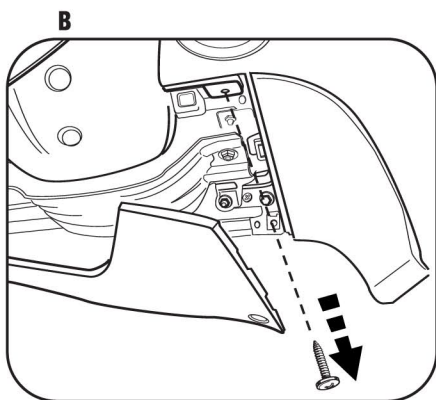
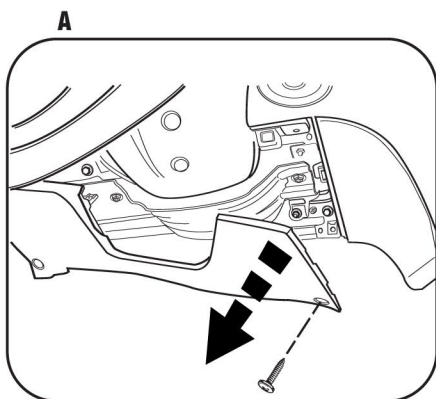

## HYUNDAI AZERA 2006-2009

- 5** Remove (3) Phillips screws from the top of the radio trim panel. (Figure D)
- 6** Remove (2) Phillips screws from under radio trim panel. (Figure E)
- 7** Unclip and remove the entire trim panel surrounding the radio. (Figure F)
- 8** Remove (4) Phillips screws securing the radio. Unplug and remove radio. (Figure G)

*Continue to kit assembly.*

**D**

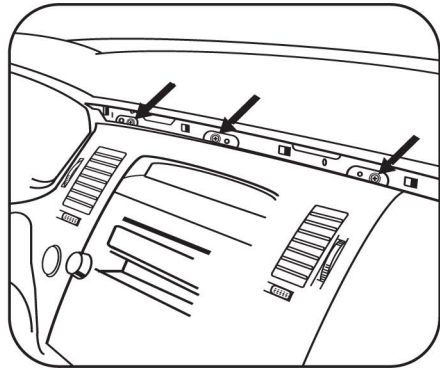

**E**

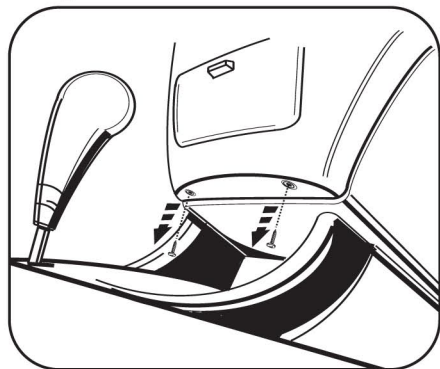

**F**

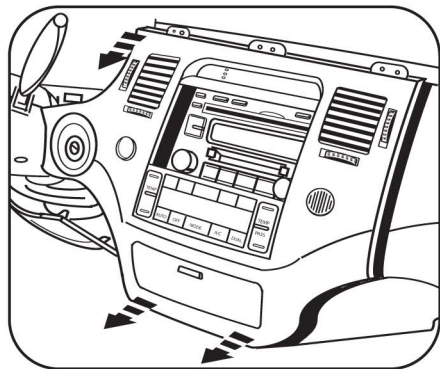

**G**

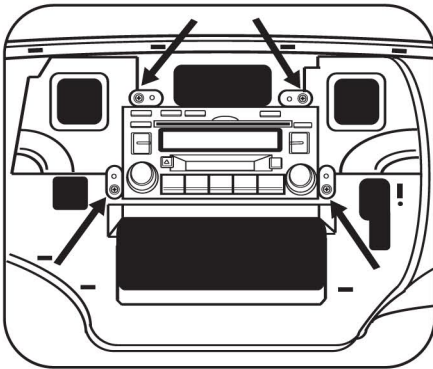

## DOUBLE DIN RADIO PROVISION

*\*Note: Refer also to the instructions included with the aftermarket radio.*

- 1 Snap the Double DIN brackets to the outside edge of the Double DIN trim plate. (Figure A)
- 2 Slide the Double DIN radio into the bracket/trim plate assembly and secure the radio to the assembly using the screws supplied with the radio. (Figure B)

*Continue to final assembly.*

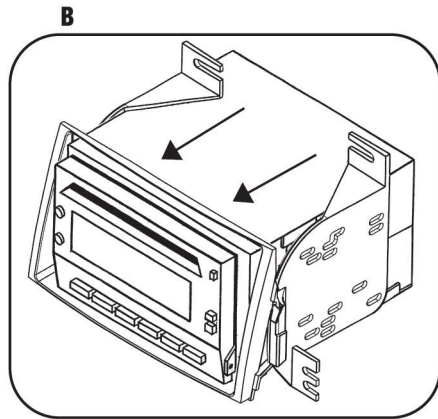
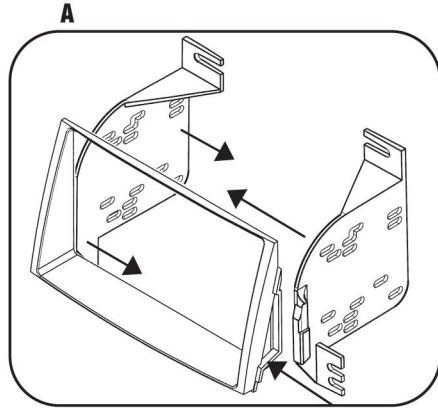

## STACKED ISO UNITS PROVISION

*\*Note: Refer also to the instructions included with the aftermarket radio.*

- 1 Snap the Double DIN brackets to the outside edge of the Double DIN trim plate. (Figure A)
- 2 Slide the stacked ISO units into the bracket/radio housing assembly and secure the units to the kit using the screws supplied with the units. (Figure B)

*Continue to final assembly.*

